



Your technology partner for cost-effective machining

FixReam 700

FixReam 700

Sustainable high-performance reamers

With the FixReam 700 reamers, MAPAL is launching a sustainable tool onto the market. The cylindrical shank reamers with brazed cutting edges are characterised by their reusability, which is achieved by replacing the cutting edges and regrinding.

A tool can be reground up to twice before new cutting edges have to be brazed in. After this, two regrinds, another change of cutting edge and a further two regrinds are possible. One reamer therefore has a service life of nine times.

During servicing, the tool is minimally widened with an expansion screw, allowing the chamfer and diameter to be precisely reground. This reduces tool costs by up to 15 per cent compared to versions without an expansion function.

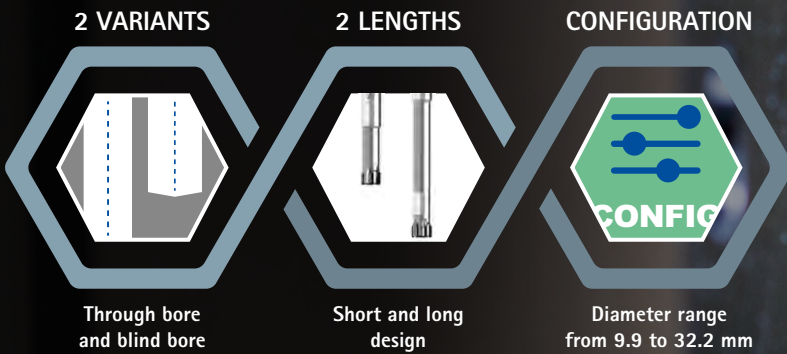
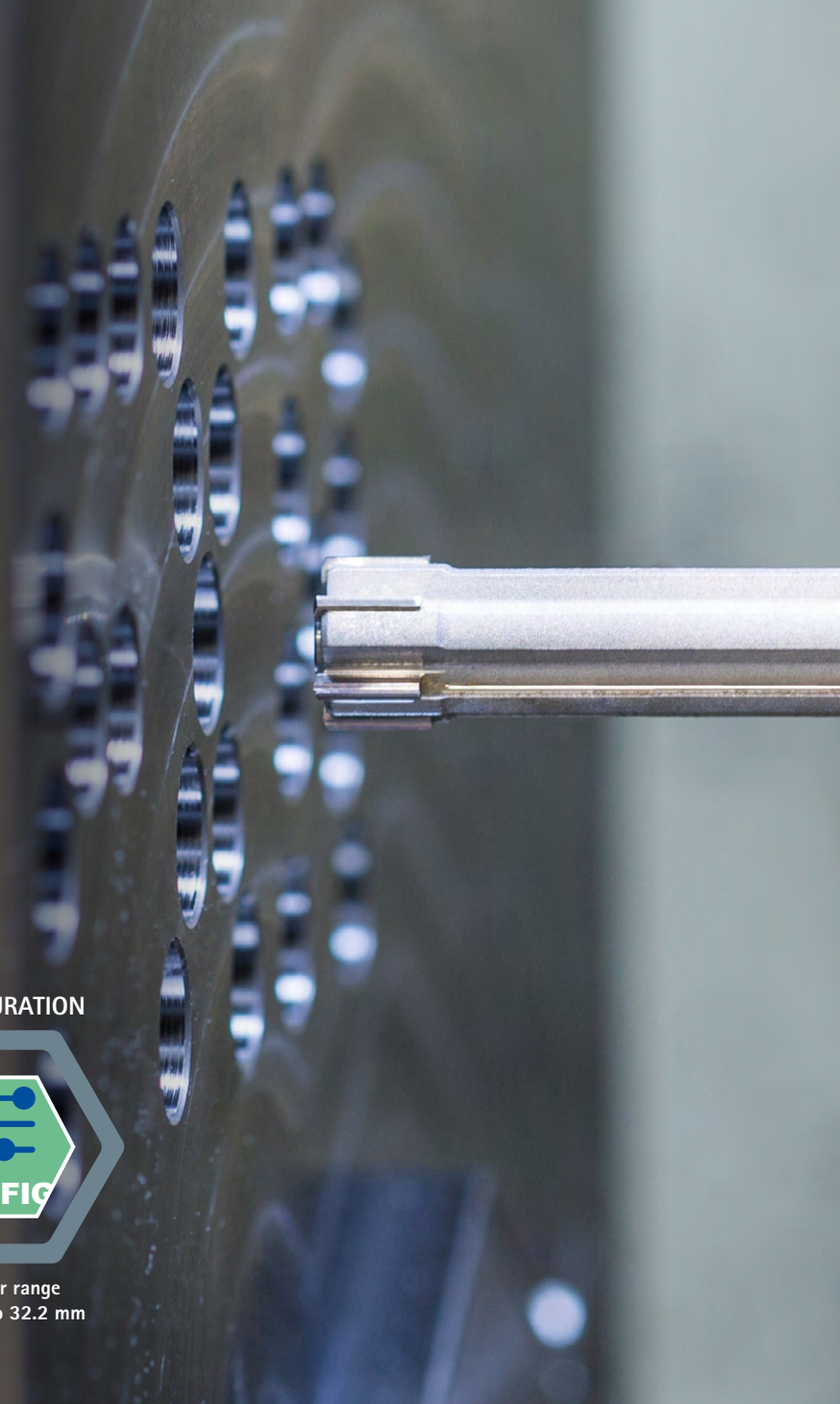

MATERIAL SUITABILITY

Suitable for all material groups **P M K N S**





Find out more about the
FixReam 700 reamers

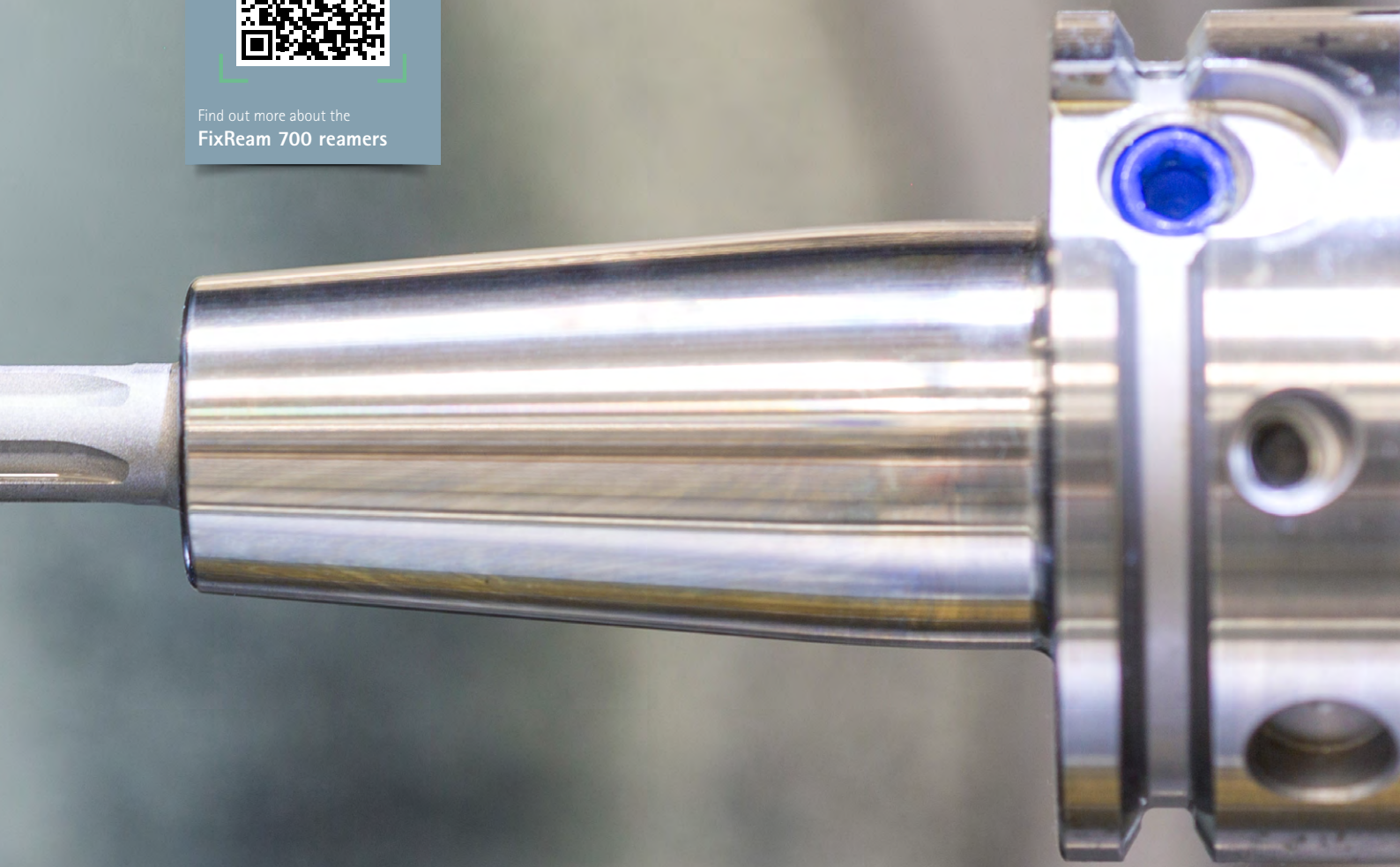

UP TO 9 TOOL USES POSSIBLE

Sustainable, resource-saving and cost-effective



FixReam 700 life cycle

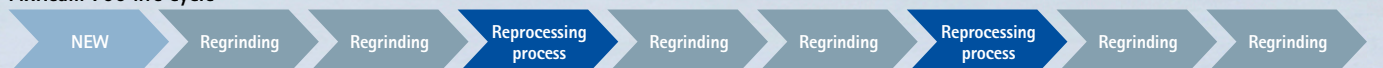

Article overview FixReam 700

Product-class	Type of bore	Material suitability												
		P					M	K	N			S		
		1-2	3	4	5	6	1-3	1-2	1	2	3	1-3	4-5	
Performance LINE	Through bore	■	■						■					
				■		■								
		■	■	■	■									
									■*					
										■	■			
	Blind bore	■	■											
				■		■								
		■	■	■	■									
									■*					
										■	■			

* For surfaces Ra < 2 µm

Configurable features



Diameter



Bore diameter tolerance ≥ IT6:

- Diameter freely selectable in increments of 0.001 mm
- Can be ordered in tolerance ≥ IT6



G variants:

- Diameter freely selectable in increments of 0.001 mm
- Can be ordered from tolerances ≥ 5 / 3 µm (G variant, see page 35)

FXR700

Expanding design, long, for through bore

Dimensions of configurable series IT6

d ₁	d ₂	l ₁	l ₂	l ₃	l ₄	l ₅	z
9,900 - 15,899	12	160	8	45	115	110	6
15,900 - 18,899	16	180	12	50	130	125	6
18,900 - 25,899	20	200	12	60	140	135	6
25,900 - 32,200	25	210	12	60	150	145	6

FXR702

Expanding design, short, for through bore

Dimensions of configurable series IT6

d ₁	d ₂	l ₁	l ₂	l ₃	l ₄	l ₅	z
9,900 - 15,899	12	95	8	45	50	45	6
15,900 - 18,899	16	100	12	50	50	45	6
18,900 - 25,899	20	120	12	60	60	55	6
25,900 - 32,200	25	135	12	60	75	70	6

Step 1:
Type of bore



Step 2:
Material suitability



Step 3:
Design





Step 4:
Product category



Step 5:
Preconfigured diameters or configuration



	Design			Preferred series			
	d ₁	Lead	Cutting material	Long version	Page	Short version	Page
9.900 - 32.200		LA1G	CU111	FXR700 	7	FXR702 	13
		LC1G	HP421		8		14
		LA1G	HP905		9		15
		LA1G	CP905		10		16
		LA1G	HP622		11		17
		LC1G	HP625		12		18
		9.900 - 32.200			LB1G		CU111
LD1G	HP421			20	26		
LB1G	HP905			21	27		
LB1G	CP905			22	28		
LB1G	HP622			23	29		
LD1G	HP625			24	30		

FXR705

Expanding design, long, for blind bore

Dimensions of configurable series IT6

d ₁	d ₂	l ₁	l ₂	l ₃	l ₄	l ₅	z
9,900 - 15,899	12	160	8	45	115	100	6
15,900 - 18,990	16	180	12	50	130	113	6
18,900 - 25,899	20	200	12	60	140	120	6
25,900 - 32,200	25	210	12	60	150	130	6

FXR703

Expanding design, short, for blind bore

Dimensions of configurable series IT6

d ₁	d ₂	l ₁	l ₂	l ₃	l ₄	l ₅	z
9,900 - 15,899	12	95	8	45	50	38	6
15,899 - 18,899	16	100	12	50	50	38	6
18,900 - 25,899	20	120	12	60	60	45	6
25,900 - 32,200	25	135	12	60	75	60	6

FixReam 700

Reconditioning enables the cost per part to be considerably reduced

The FixReam 700 was developed to increase economic efficiency through effective reconditioning. Thanks to an expansion screw, the multi-bladed reamer can be expanded in diameter before regrinding. As a result, all functional surfaces can be reground, both on the lead as well as on the tool diameter. This allows the reamer to be reused up to 9 times.

1 30% better roundness and cylindrical form

- Thanks to patented geometry

2 Optimal chip shape

- New, innovative leads enable better chip shape

3 Up to 9 uses

- Possible through expansion screw for compensation before regrinding



Features

Configurable features:

- \varnothing area: 9.900 - 32.200 mm
- Bore diameter: Tolerance \geq IT6
- Tool diameter: Tolerance $\geq 3 \mu\text{m}$ in increments of 0.001 mm

Dimensions:

- Available as a short and long design
- For through bores and blind bores
- Preferred series available from stock in H7: 10.000 - 32.000 mm

TOOL LIFE ACHIEVED [%]

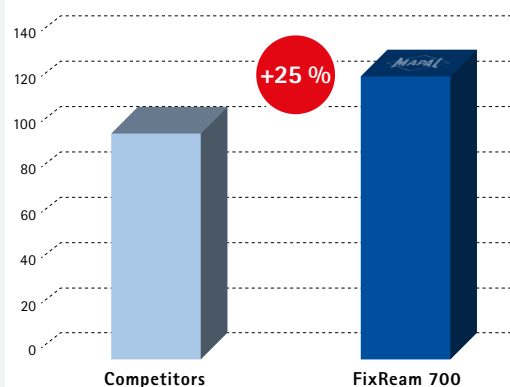

Workpiece material: 42CrMoS4

Machining length: 45.000 mm
 Nominal \varnothing : 12.000 mm
 n: 3448 rpm
 v_f : 3448 mm/min
 v_c : 130 m/min
 z: 6

FixReam 700

Expanding design, long, for through bore
FXR700

Design:

Reamer diameter: 9.900 - 32.200 mm
Lead: LA1G
Cutting material: CU111
Uncoated cermet

Application:

The expansion system is therefore only suitable for compensation prior to re-grinding and not for setting or re-adjusting the diameter.

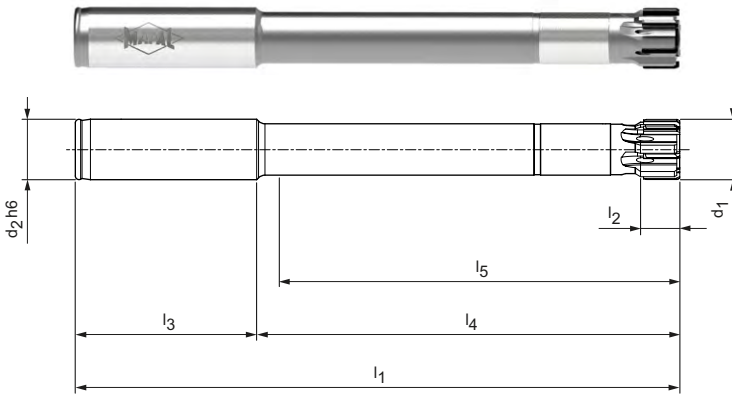

Preferred series in H7

d ₁ H7	Dimensions						z	Specification	Order no.
	d ₂ h6	l ₁	l ₂	l ₃	l ₄	l ₅			
10,000	12	160	8	45	115	110	6	FXR700Ø10.000H7LA1G-CU111	31460971
12,000	12	160	8	45	115	110	6	FXR700Ø12.000H7LA1G-CU111	31460972
14,000	12	160	8	45	115	110	6	FXR700Ø14.000H7LA1G-CU111	31460973
16,000	16	180	12	50	130	125	6	FXR700Ø16.000H7LA1G-CU111	31460974
18,000	16	180	12	50	130	125	6	FXR700Ø18.000H7LA1G-CU111	31460975
20,000	20	200	12	60	140	135	6	FXR700Ø20.000H7LA1G-CU111	31460976
22,000	20	200	12	60	140	135	6	FXR700Ø22.000H7LA1G-CU111	31460977
24,000	20	200	12	60	140	135	6	FXR700Ø24.000H7LA1G-CU111	31460978
25,000	20	200	12	60	140	135	6	FXR700Ø25.000H7LA1G-CU111	31460979
28,000	25	210	12	60	150	145	6	FXR700Ø28.000H7LA1G-CU111	31460980
30,000	25	210	12	60	150	145	6	FXR700Ø30.000H7LA1G-CU111	31460981
32,000	25	210	12	60	150	145	6	FXR700Ø32.000H7LA1G-CU111	31460982

Configurable features



Bore diameter tolerance ≥ IT6:
- Diameter freely selectable in increments of 0.001 mm
- Can be ordered in tolerance ≥ IT6

Specification:
FXR700Ø[Diameter][Tolerance]LA1G-CU111

G variants:
- Diameter freely selectable in increments of 0.001 mm
- Can be ordered from tolerances ≥ 3 µm (G variant, see page 35)

G variant specification:
FXR700GØ[Diameter][Tolerance]LA1G-CU111

Dimensions of configurable series IT6

d ₁	d ₂	l ₁	l ₂	l ₃	l ₄	l ₅	z
9,900 - 15,899	12	160	8	45	115	110	6
15,900 - 18,899	16	180	12	50	130	125	6
18,900 - 25,899	20	200	12	60	140	135	6
25,900 - 32,200	25	210	12	60	150	145	6

IT6 tolerance example:
FXR700Ø16.350H6LA1G-CU111

Bore diameter d₁ = 16.350 H6

G variant example:
FXR700GØ16.350-3LA1G-CU111

Special tool diameter d₁ = 16.350 -3 µm

Dimensions in mm.

For cutting data recommendations, see end of chapter.

FixReam 700

Expanding design, long, for through bore
FXR700

Design:

Reamer diameter: 9.900 - 32.200 mm
Lead: LC1G
Cutting material: HP421
Coated solid carbide

Application:

The expansion system is therefore only suitable for compensation prior to re-grinding and not for setting or re-adjusting the diameter.

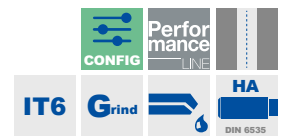
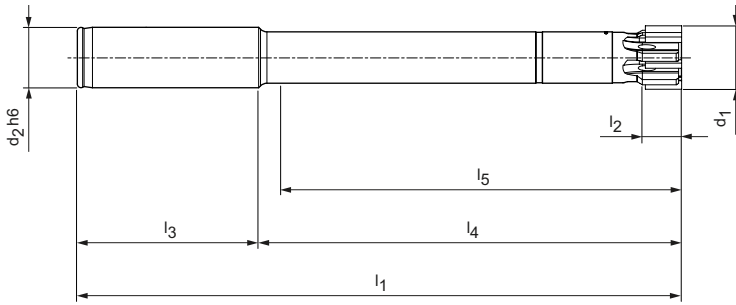

Configurable features



Bore diameter tolerance ≥ IT6:
- Diameter freely selectable in increments of 0.001 mm
- Can be ordered in tolerance ≥ IT6

Specification:
FXR700Ø[Diameter][Tolerance]LC1G-HP421

G variants:
- Diameter freely selectable in increments of 0.001 mm
- Can be ordered from tolerances ≥ 5 µm (G variant, see page 35)

G variant specification:
FXR700GØ[Diameter][Tolerance]LC1G-HP421

Dimensions of configurable series IT6

d ₁	d ₂	l ₁	l ₂	l ₃	l ₄	l ₅	z
9,900 - 15,899	12	160	8	45	115	110	6
15,900 - 18,899	16	180	12	50	130	125	6
18,900 - 25,899	20	200	12	60	140	135	6
25,900 - 32,200	25	210	12	60	150	145	6

IT6 tolerance example:
FXR700Ø16.350H6LC1G-HP421

Bore diameter d₁ = 16.350 H6

G variant example:
FXR700GØ16.350-5LC1G-HP421

Special tool diameter d₁ = 16.350 -5 µm

FixReam 700

Expanding design, long, for through bore
FXR700

Design:

Reamer diameter: 9.900 - 32.200 mm
Lead: LA1G
Cutting material: HP905
Coated solid carbide

Application:

The expansion system is therefore only suitable for compensation prior to re-grinding and not for setting or re-adjusting the diameter.

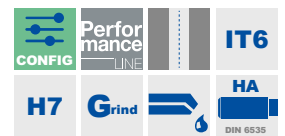
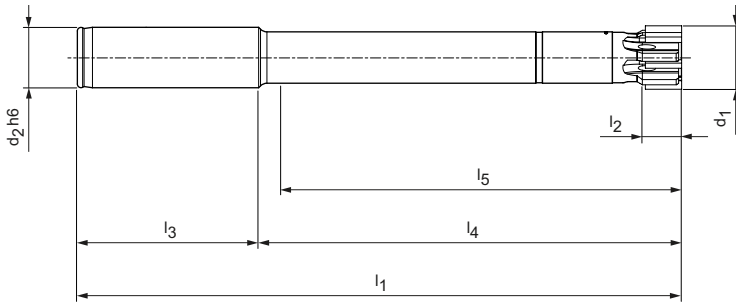

Preferred series in H7

d ₁ H7	Dimensions						z	Specification	Order no.
	d ₂ h6	l ₁	l ₂	l ₃	l ₄	l ₅			
10,000	12	160	8	45	115	110	6	FXR700Ø10.000H7LA1G-HP905	31553765
12,000	12	160	8	45	115	110	6	FXR700Ø12.000H7LA1G-HP905	31553766
14,000	12	160	8	45	115	110	6	FXR700Ø14.000H7LA1G-HP905	31553767
16,000	16	180	12	50	130	125	6	FXR700Ø16.000H7LA1G-HP905	31553768
18,000	16	180	12	50	130	125	6	FXR700Ø18.000H7LA1G-HP905	31553769
20,000	20	200	12	60	140	135	6	FXR700Ø20.000H7LA1G-HP905	31553800
22,000	20	200	12	60	140	135	6	FXR700Ø22.000H7LA1G-HP905	31553801
24,000	20	200	12	60	140	135	6	FXR700Ø24.000H7LA1G-HP905	31553802
25,000	20	200	12	60	140	135	6	FXR700Ø25.000H7LA1G-HP905	31553803
28,000	25	210	12	60	150	145	6	FXR700Ø28.000H7LA1G-HP905	31553804
30,000	25	210	12	60	150	145	6	FXR700Ø30.000H7LA1G-HP905	31553805
32,000	25	210	12	60	150	145	6	FXR700Ø32.000H7LA1G-HP905	31553806

Configurable features



Bore diameter tolerance ≥ IT6:
- Diameter freely selectable in increments of 0.001 mm
- Can be ordered in tolerance ≥ IT6

Specification:
FXR700Ø[Diameter][Tolerance]LA1G-HP905

G variants:
- Diameter freely selectable in increments of 0.001 mm
- Can be ordered from tolerances ≥ 5 µm (G variant, see page 35)

G variant specification:
FXR700GØ[Diameter][Tolerance]LA1G-HP905

Dimensions of configurable series IT6

d ₁	d ₂	l ₁	l ₂	l ₃	l ₄	l ₅	z
9,900 - 15,899	12	160	8	45	115	100	6
15,900 - 18,990	16	180	12	50	130	113	6
18,900 - 25,899	20	200	12	60	140	120	6
25,900 - 32,200	25	210	12	60	150	130	6

IT6 tolerance example:
FXR700Ø16.350H6LA1G-HP905

Bore diameter d₁ = 16.350 H6

G variant example:
FXR700GØ16.350-5LA1G-HP905

Special tool diameter d₁ = 16.350 -5 µm

Dimensions in mm.
For cutting data recommendations, see end of chapter.

FixReam 700

Expanding design, long, for through bore
FXR700

Design:

Reamer diameter: 9.900 - 32.200 mm
Lead: LA1G
Cutting material: CP905
Coated cermet

Application:

For surfaces $Ra < 2 \mu m$.
The expansion system is therefore only suitable for compensation prior to re-grinding and not for setting or re-adjusting the diameter.

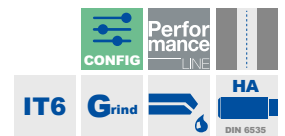
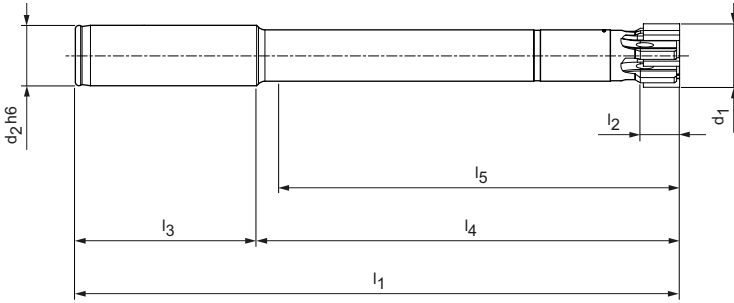

Configurable features



Bore diameter tolerance $\geq IT6$:
- Diameter freely selectable in increments of 0.001 mm
- Can be ordered in tolerance $\geq IT6$

Specification:
FXR700Ø[Diameter][Tolerance]LA1G-CP905

G variants:
- Diameter freely selectable in increments of 0.001 mm
- Can be ordered from tolerances $\geq 5 \mu m$ (G variant, see page 35)

G variant specification:
FXR700GØ[Diameter][Tolerance]LA1G-CP905

Dimensions of configurable series IT6

d_1	d_2	l_1	l_2	l_3	l_4	l_5	z
9,900 - 15,899	12	160	8	45	115	110	6
15,900 - 18,899	16	180	12	50	130	125	6
18,900 - 25,899	20	200	12	60	140	135	6
25,900 - 32,200	25	210	12	60	150	145	6

IT6 tolerance example:
FXR700Ø16.350H6LA1G-CP905

Bore diameter $d_1 = 16.350 H6$

G variant example:
FXR700GØ16.350-5LA1G-CP905

Special tool diameter $d_1 = 16.350 -5 \mu m$

FixReam 700

Expanding design, long, for through bore
FXR700

Design:

Reamer diameter: 9.900 - 32.200 mm
Lead: LA1G
Cutting material: HP622
Coated solid carbide

Application:

The expansion system is therefore only suitable for compensation prior to re-grinding and not for setting or re-adjusting the diameter.

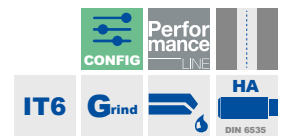
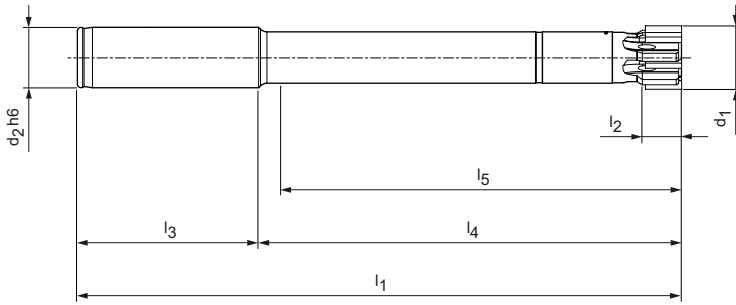

Configurable features



Bore diameter tolerance ≥ IT6:
- Diameter freely selectable in increments of 0.001 mm
- Can be ordered in tolerance ≥ IT6

Specification:
FXR700Ø[Diameter][Tolerance]LA1G-HP622

G variants:
- Diameter freely selectable in increments of 0.001 mm
- Can be ordered from tolerances ≥ 5 µm (G variant, see page 35)

G variant specification:
FXR700GØ[Diameter][Tolerance]LA1G-HP622

Dimensions of configurable series IT6

d ₁	d ₂	l ₁	l ₂	l ₃	l ₄	l ₅	z
9,900 - 15,899	12	160	8	45	115	110	6
15,900 - 18,899	16	180	12	50	130	125	6
18,900 - 25,899	20	200	12	60	140	135	6
25,900 - 32,200	25	210	12	60	150	145	6

IT6 tolerance example:
FXR700Ø16.350H6LA1G-HP622

Bore diameter d₁ = 16.350 H6

G variant example:
FXR700GØ16.350-5LA1G-HP622

Special tool diameter d₁ = 16.350 -5 µm

FixReam 700

Expanding design, long, for through bore
FXR700

Design:

Reamer diameter: 9.900 - 32.200 mm
Lead: LC1G
Cutting material: HP625
Coated solid carbide

Application:

The expansion system is therefore only suitable for compensation prior to re-grinding and not for setting or re-adjusting the diameter.

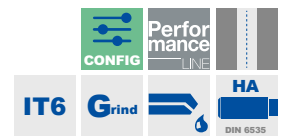
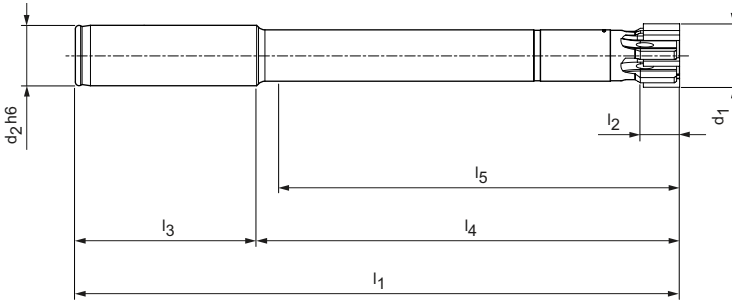

Configurable features



Bore diameter tolerance ≥ IT6:
- Diameter freely selectable in increments of 0.001 mm
- Can be ordered in tolerance ≥ IT6

Specification:
FXR700Ø[Diameter][Tolerance]LC1G-HP625

G variants:
- Diameter freely selectable in increments of 0.001 mm
- Can be ordered from tolerances ≥ 5 µm (G variant, see page 35)

G variant specification:
FXR700GØ[Diameter][Tolerance]LC1G-HP625

Dimensions of configurable series IT6

d ₁	d ₂	l ₁	l ₂	l ₃	l ₄	l ₅	z
9,900 - 15,899	12	160	8	45	115	110	6
15,900 - 18,899	16	180	12	50	130	125	6
18,900 - 25,899	20	200	12	60	140	135	6
25,900 - 32,200	25	210	12	60	150	145	6

IT6 tolerance example:
FXR700Ø16.350H6LC1G-HP625

Bore diameter d₁ = 16.350 H6

G variant example:
FXR700GØ16.350-5LC1G-HP625

Special tool diameter d₁ = 16.350 -5 µm

FixReam 700

Expanding design, short, for through bore
FXR702

Design:

Reamer diameter: 9.900 - 32.200 mm
Lead: LA1G
Cutting material: CU111
Uncoated cermet

Application:

The expansion system is therefore only suitable for compensation prior to re-grinding and not for setting or re-adjusting the diameter.

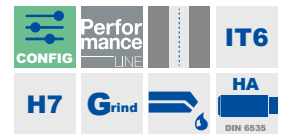
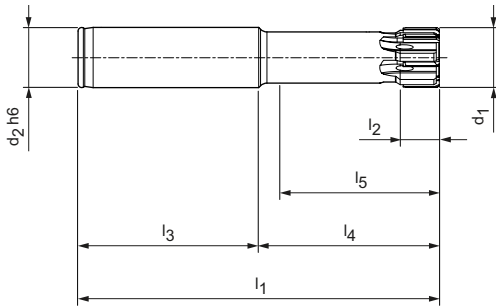

Preferred series in H7

d ₁ H7	Dimensions						z	Specification	Order no.
	d ₂ h6	l ₁	l ₂	l ₃	l ₄	l ₅			
10,000	12	95	8	45	50	45	6	FXR702Ø10.000H7LA1G-CU111	31460929
12,000	12	95	8	45	50	45	6	FXR702Ø12.000H7LA1G-CU111	31460960
14,000	12	95	8	45	50	45	6	FXR702Ø14.000H7LA1G-CU111	31460961
16,000	16	100	12	50	50	45	6	FXR702Ø16.000H7LA1G-CU111	31460962
18,000	16	100	12	50	50	45	6	FXR702Ø18.000H7LA1G-CU111	31460963
20,000	20	120	12	60	60	55	6	FXR702Ø20.000H7LA1G-CU111	31460964
22,000	20	120	12	60	60	55	6	FXR702Ø22.000H7LA1G-CU111	31460965
24,000	20	120	12	60	60	55	6	FXR702Ø24.000H7LA1G-CU111	31460966
25,000	20	120	12	60	60	55	6	FXR702Ø25.000H7LA1G-CU111	31460967
28,000	25	135	12	60	75	70	6	FXR702Ø28.000H7LA1G-CU111	31460968
30,000	25	135	12	60	75	70	6	FXR702Ø30.000H7LA1G-CU111	31460969
32,000	25	135	12	60	75	70	6	FXR702Ø32.000H7LA1G-CU111	31460970

Configurable features



Bore diameter tolerance ≥ IT6:

- Diameter freely selectable in increments of 0.001 mm
- Can be ordered in tolerance ≥ IT6

Specification:

FXR702Ø[Diameter][Tolerance]LA1G-CU111

G variants:

- Diameter freely selectable in increments of 0.001 mm
- Can be ordered from tolerances ≥ 3 μm (G variant, see page 35)

G variant specification:

FXR702GØ[Diameter][Tolerance]LA1G-CU111

Dimensions of configurable series IT6

d ₁	d ₂	l ₁	l ₂	l ₃	l ₄	l ₅	z
9,900 - 15,899	12	95	8	45	50	45	6
15,900 - 18,899	16	100	12	50	50	45	6
18,900 - 25,899	20	120	12	60	60	55	6
25,900 - 32,200	25	135	12	60	75	70	6

IT6 tolerance example:

FXR702Ø16.350H6LA1G-CU111

Bore diameter d₁ = 16.350 H6

G variant example:

FXR702GØ16.350-3LA1G-CU111

Special tool diameter d₁ = 16.350 -3 μm

Dimensions in mm.

For cutting data recommendations, see end of chapter.

FixReam 700

Expanding design, short, for through bore
FXR702

Design:

Reamer diameter: 9.900 - 32.200 mm
Lead: LC1G
Cutting material: HP421
Coated solid carbide

Application:

The expansion system is therefore only suitable for compensation prior to re-grinding and not for setting or re-adjusting the diameter.

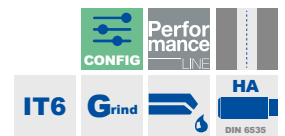
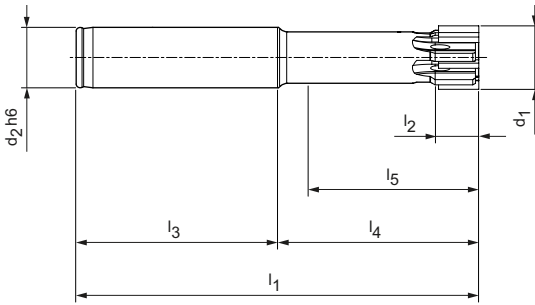

Configurable features



Bore diameter tolerance ≥ IT6:
- Diameter freely selectable in increments of 0.001 mm
- Can be ordered in tolerance ≥ IT6

Specification:
FXR702Ø[Diameter][Tolerance]LC1G-HP421

G variants:
- Diameter freely selectable in increments of 0.001 mm
- Can be ordered from tolerances ≥ 5 µm (G variant, see page 35)

G variant specification:
FXR702GØ[Diameter][Tolerance]LC1G-HP421

Dimensions of configurable series IT6

d ₁	d ₂	l ₁	l ₂	l ₃	l ₄	l ₅	z
9,900 - 15,899	12	95	8	45	50	45	6
15,900 - 18,990	16	100	12	50	50	45	6
18,900 - 25,899	20	120	12	60	60	55	6
25,900 - 32,200	25	135	12	60	75	70	6

IT6 tolerance example:
FXR702Ø16.350H6LC1G-HP421

Bore diameter d₁ = 16.350 H6

G variant example:
FXR702GØ16.350-5LC1G-HP421

Special tool diameter d₁ = 16.350 -5 µm

FixReam 700

Expanding design, short, for through bore
FXR702

Design:

Reamer diameter: 9.900 - 32.200 mm
Lead: LA1G
Cutting material: HP905
Coated solid carbide

Application:

The expansion system is therefore only suitable for compensation prior to re-grinding and not for setting or re-adjusting the diameter.

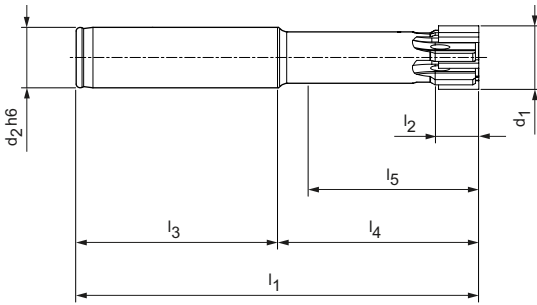

Preferred series in H7

d ₁ H7	Dimensions						z	Specification	Order no.
	d ₂ h6	l ₁	l ₂	l ₃	l ₄	l ₅			
10,000	12	95	8	45	50	45	6	FXR702Ø10.000H7LA1G-HP905	31553807
12,000	12	95	8	45	50	45	6	FXR702Ø12.000H7LA1G-HP905	31553808
14,000	12	95	8	45	50	45	6	FXR702Ø14.000H7LA1G-HP905	31553809
16,000	16	100	12	50	50	45	6	FXR702Ø16.000H7LA1G-HP905	31553810
18,000	16	100	12	50	50	45	6	FXR702Ø18.000H7LA1G-HP905	31553811
20,000	20	120	12	60	60	55	6	FXR702Ø20.000H7LA1G-HP905	31553812
22,000	20	120	12	60	60	55	6	FXR702Ø22.000H7LA1G-HP905	31553813
24,000	20	120	12	60	60	55	6	FXR702Ø24.000H7LA1G-HP905	31553814
25,000	20	120	12	60	60	55	6	FXR702Ø25.000H7LA1G-HP905	31553815
28,000	25	135	12	60	75	70	6	FXR702Ø28.000H7LA1G-HP905	31553816
30,000	25	135	12	60	75	70	6	FXR702Ø30.000H7LA1G-HP905	31553817
32,000	25	135	12	60	75	70	6	FXR702Ø32.000H7LA1G-HP905	31553818

Configurable features



Bore diameter tolerance ≥ IT6:
- Diameter freely selectable in increments of 0.001 mm
- Can be ordered in tolerance ≥ IT6

Specification:
FXR702Ø[**Diameter**][**Tolerance**]LA1G-HP905

G variants:
- Diameter freely selectable in increments of 0.001 mm
- Can be ordered from tolerances ≥ 5 µm (G variant, see page 35)

G variant specification:
FXR702GØ[**Diameter**][**Tolerance**]LA1G-HP905

Dimensions of configurable series IT6

d ₁	d ₂	l ₁	l ₂	l ₃	l ₄	l ₅	z
9,900 - 15,899	12	95	8	45	50	45	6
15,900 - 18,899	16	100	12	50	50	45	6
18,900 - 25,899	20	120	12	60	60	55	6
25,900 - 32,200	25	135	12	60	75	70	6

IT6 tolerance example:
FXR702Ø**16.350**H6LA1G-HP905

Bore diameter d₁ = 16.350 H6

G variant example:
FXR702GØ**16.350**-5LA1G-HP905

Special tool diameter d₁ = 16.350 -5 µm

Dimensions in mm.
For cutting data recommendations, see end of chapter.

FixReam 700

Expanding design, short, for through bore
FXR702

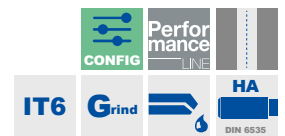
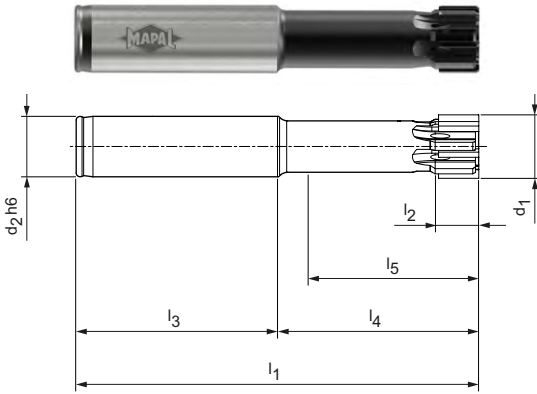

Design:
Reamer diameter: 9.900 - 32.200 mm
Lead: LA1G
Cutting material: CP905
Coated cermet

Application:
For surfaces Ra < 2 µm.
The expansion system is therefore only suitable for compensation prior to re-grinding and not for setting or re-adjusting the diameter.

Configurable features



Bore diameter tolerance ≥ IT6:
- Diameter freely selectable in increments of 0.001 mm
- Can be ordered in tolerance ≥ IT6

Specification:
FXR702Ø[Diameter][Tolerance]LA1G-CP905

G variants:
- Diameter freely selectable in increments of 0.001 mm
- Can be ordered from tolerances ≥ 5 µm (G variant, see page 35)

G variant specification:
FXR702GØ[Diameter][Tolerance]LA1G-CP905

Dimensions of configurable series IT6

d ₁	d ₂	l ₁	l ₂	l ₃	l ₄	l ₅	z
9,900 - 15,899	12	95	8	45	50	45	6
15,900 - 18,990	16	100	12	50	50	45	6
18,900 - 25,899	20	120	12	60	60	55	6
25,900 - 32,200	25	135	12	60	75	70	6

IT6 tolerance example:
FXR702Ø16.350H6LA1G-CP905

Bore diameter d₁ = 16.350 H6

G variant example:
FXR702GØ16.350-5LA1G-CP905

Special tool diameter d₁ = 16.350 -5 µm

FixReam 700

Expanding design, short, for through bore
FXR702

Design:

Reamer diameter: 9.900 - 32.200 mm
Lead: LA1G
Cutting material: HP622
Coated solid carbide

Application:

The expansion system is therefore only suitable for compensation prior to re-grinding and not for setting or re-adjusting the diameter.

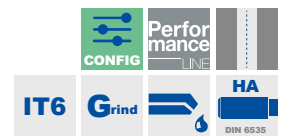
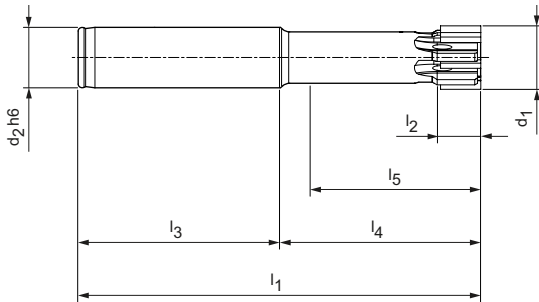

Configurable features



Bore diameter tolerance \geq IT6:

- Diameter freely selectable in increments of 0.001 mm
- Can be ordered in tolerance \geq IT6

Specification:

FXR702Ø[Diameter][Tolerance]LA1G-HP622

G variants:

- Diameter freely selectable in increments of 0.001 mm
- Can be ordered from tolerances $\geq 5 \mu\text{m}$ (G variant, see page 35)

G variant specification:

FXR702GØ[Diameter][Tolerance]LA1G-HP622

Dimensions of configurable series IT6

d_1	d_2	l_1	l_2	l_3	l_4	l_5	z
9,900 - 15,899	12	95	8	45	50	45	6
15,900 - 18,990	16	100	12	50	50	45	6
18,900 - 25,899	20	120	12	60	60	55	6
25,900 - 32,200	25	135	12	60	75	70	6

IT6 tolerance example:

FXR702Ø16.350H6LA1G-HP622

Bore diameter $d_1 = 16.350 \text{ H6}$

G variant example:

FXR702GØ16.350-5LA1G-HP622

Special tool diameter $d_1 = 16.350 -5 \mu\text{m}$

FixReam 700

Expanding design, short, for through bore
FXR702

Design:

Reamer diameter: 9.900 - 32.200 mm
Lead: LC1G
Cutting material: HP625
Coated solid carbide

Application:

The expansion system is therefore only suitable for compensation prior to re-grinding and not for setting or re-adjusting the diameter.

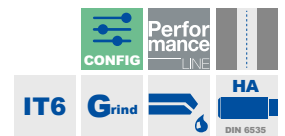
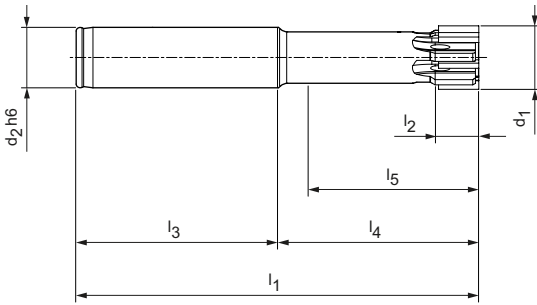

Configurable features



Bore diameter tolerance ≥ IT6:
- Diameter freely selectable in increments of 0.001 mm
- Can be ordered in tolerance ≥ IT6

Specification:
FXR702Ø[Diameter][Tolerance]LC1G-HP625

G variants:
- Diameter freely selectable in increments of 0.001 mm
- Can be ordered from tolerances ≥ 5 µm (G variant, see page 35)

G variant specification:
FXR702GØ[Diameter][Tolerance]LC1G-HP625

Dimensions of configurable series IT6

d ₁	d ₂	l ₁	l ₂	l ₃	l ₄	l ₅	z
9,900 - 15,899	12	95	8	45	50	45	6
15,900 - 18,990	16	100	12	50	50	45	6
18,900 - 25,899	20	120	12	60	60	55	6
25,900 - 32,200	25	135	12	60	75	70	6

IT6 tolerance example:
FXR702Ø16.350H6LC1G-HP625

Bore diameter d₁ = 16.350 H6

G variant example:
FXR702GØ16.350-5LC1G-HP625

Special tool diameter d₁ = 16.350 -5 µm

FixReam 700

Expanding design, long, for blind bore
FXR705

Design:

Reamer diameter: 9.900 - 32.200 mm
Lead: LB1G
Cutting material: CU111
Uncoated cermet

Application:

The expansion system is therefore only suitable for compensation prior to re-grinding and not for setting or re-adjusting the diameter.

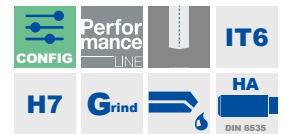
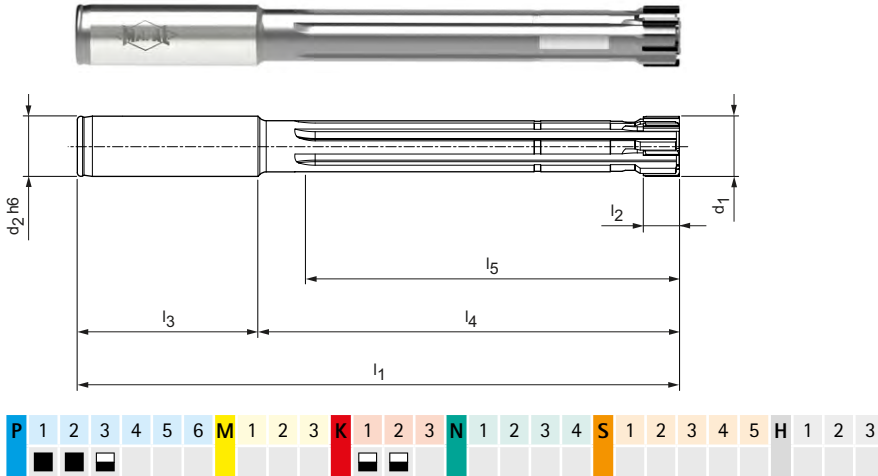

Preferred series in H7

d ₁ H7	Dimensions						z	Specification	Order no.
	d ₂ h6	l ₁	l ₂	l ₃	l ₄	l ₅			
10,000	12	160	8	45	115	100	6	FXR705Ø10.000H7LB1G-CU111	31460995
12,000	12	160	8	45	115	100	6	FXR705Ø12.000H7LB1G-CU111	31460996
14,000	12	160	8	45	115	100	6	FXR705Ø14.000H7LB1G-CU111	31460997
16,000	16	180	12	50	130	114	6	FXR705Ø16.000H7LB1G-CU111	31460998
18,000	16	180	12	50	130	115	6	FXR705Ø18.000H7LB1G-CU111	31460999
20,000	20	200	12	60	140	120	6	FXR705Ø20.000H7LB1G-CU111	31461000
22,000	20	200	12	60	140	120	6	FXR705Ø22.000H7LB1G-CU111	31461001
24,000	20	200	12	60	140	120	6	FXR705Ø24.000H7LB1G-CU111	31461002
25,000	20	200	12	60	140	120	6	FXR705Ø25.000H7LB1G-CU111	31461003
28,000	25	210	12	60	150	130	6	FXR705Ø28.000H7LB1G-CU111	31461004
30,000	25	210	12	60	150	130	6	FXR705Ø30.000H7LB1G-CU111	31461005
32,000	25	210	12	60	150	130	6	FXR705Ø32.000H7LB1G-CU111	31461006

Configurable features



Bore diameter tolerance ≥ IT6:

- Diameter freely selectable in increments of 0.001 mm
- Can be ordered in tolerance ≥ IT6

Specification:

FXR705Ø[Diameter][Tolerance]LB1G-CU111

G variants:

- Diameter freely selectable in increments of 0.001 mm
- Can be ordered from tolerances ≥ 3 μm (G variant, see page 35)

G variant specification:

FXR705GØ[Diameter][Tolerance]LB1G-CU111

Dimensions of configurable series IT6

d ₁	d ₂	l ₁	l ₂	l ₃	l ₄	l ₅	z
9,900 - 15,899	12	160	8	45	115	100	6
15,900 - 18,990	16	180	12	50	130	113	6
18,900 - 25,899	20	200	12	60	140	120	6
25,900 - 32,200	25	210	12	60	150	130	6

IT6 tolerance example:

FXR705Ø16.350H6LB1G-CU111

Bore diameter d₁ = 16.350 H6

G variant example:

FXR705GØ16.350-3LB1G-CU111

Special tool diameter d₁ = 16.350 -3 μm

Dimensions in mm.

For cutting data recommendations, see end of chapter.

FixReam 700

Expanding design, long, for blind bore
FXR705

Design:

Reamer diameter: 9.900 - 32.200 mm
Lead: LD1G
Cutting material: HP421
Coated solid carbide

Application:

The expansion system is therefore only suitable for compensation prior to re-grinding and not for setting or re-adjusting the diameter.

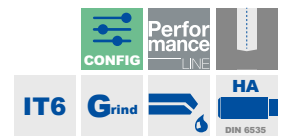
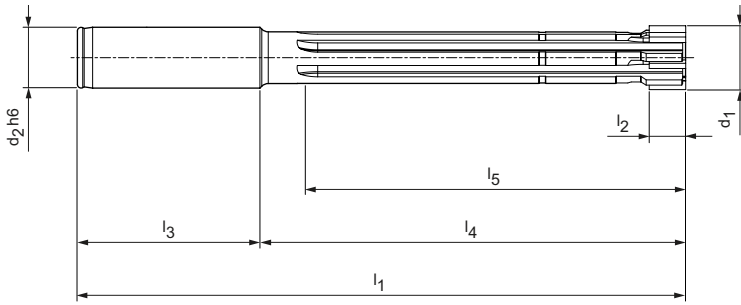

Configurable features



Bore diameter tolerance \geq IT6:
- Diameter freely selectable in increments of 0.001 mm
- Can be ordered in tolerance \geq IT6

Specification:
FXR705Ø[Diameter][Tolerance]LD1G-HP421

G variants:
- Diameter freely selectable in increments of 0.001 mm
- Can be ordered from tolerances \geq 5 μ m (G variant, see page 35)

G variant specification:
FXR705GØ[Diameter][Tolerance]LD1G-HP421

Dimensions of configurable series IT6

d_1	d_2	l_1	l_2	l_3	l_4	l_5	z
9,900 - 15,899	12	160	8	45	115	100	6
15,900 - 18,990	16	180	12	50	130	113	6
18,900 - 25,899	20	200	12	60	140	120	6
25,900 - 32,200	25	210	12	60	150	130	6

IT6 tolerance example:
FXR705Ø16.350H6LD1G-HP421

Bore diameter $d_1 = 16.350$ H6

G variant example:
FXR705GØ16.350-5LD1G-HP421

Special tool diameter $d_1 = 16.350 -5 \mu$ m

FixReam 700

Expanding design, long, for blind bore
FXR705

Design:

Reamer diameter: 9.900 - 32.200 mm
Lead: LB1G
Cutting material: HP905
Coated solid carbide

Application:

The expansion system is therefore only suitable for compensation prior to re-grinding and not for setting or re-adjusting the diameter.

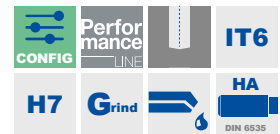
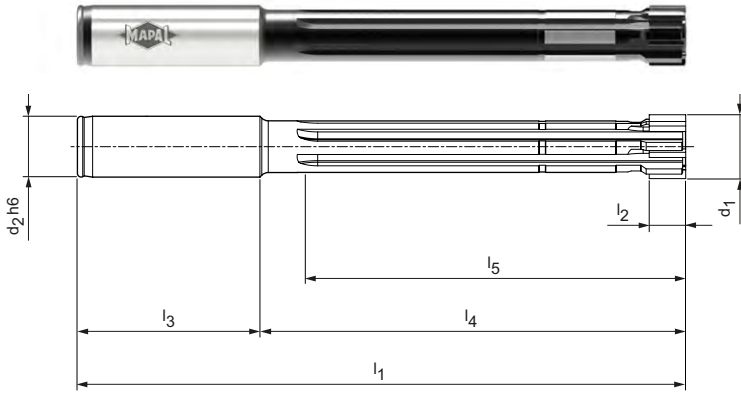

Preferred series in H7

d ₁ H7	Dimensions						z	Specification	Order no.
	d ₂ h6	l ₁	l ₂	l ₃	l ₄	l ₅			
10,000	12	160	8	45	115	100	6	FXR705Ø10.000H7LB1G-HP905	31553831
12,000	12	160	8	45	115	100	6	FXR705Ø12.000H7LB1G-HP905	31553832
14,000	12	160	8	45	115	100	6	FXR705Ø14.000H7LB1G-HP905	31553833
16,000	16	180	12	50	130	114	6	FXR705Ø16.000H7LB1G-HP905	31553834
18,000	16	180	12	50	130	115	6	FXR705Ø18.000H7LB1G-HP905	31553835
20,000	20	200	12	60	140	120	6	FXR705Ø20.000H7LB1G-HP905	31553836
22,000	20	200	12	60	140	120	6	FXR705Ø22.000H7LB1G-HP905	31553837
24,000	20	200	12	60	140	120	6	FXR705Ø24.000H7LB1G-HP905	31553838
25,000	20	200	12	60	140	120	6	FXR705Ø25.000H7LB1G-HP905	31553839
28,000	25	210	12	60	150	130	6	FXR705Ø28.000H7LB1G-HP905	31553840
30,000	25	210	12	60	150	130	6	FXR705Ø30.000H7LB1G-HP905	31553841
32,000	25	210	12	60	150	130	6	FXR705Ø32.000H7LB1G-HP905	31553842

Configurable features



Bore diameter tolerance ≥ IT6:

- Diameter freely selectable in increments of 0.001 mm
- Can be ordered in tolerance ≥ IT6

Specification:

FXR705Ø[Diameter][Tolerance]LB1G-HP905

G variants:

- Diameter freely selectable in increments of 0.001 mm
- Can be ordered from tolerances ≥ 5 μm (G variant, see page 35)

G variant specification:

FXR705GØ[Diameter][Tolerance]LB1G-HP905

Dimensions of configurable series IT6

d ₁	d ₂	l ₁	l ₂	l ₃	l ₄	l ₅	z
9,900 - 15,899	12	160	8	45	115	100	6
15,900 - 18,990	16	180	12	50	130	113	6
18,900 - 25,899	20	200	12	60	140	120	6
25,900 - 32,200	25	210	12	60	150	130	6

IT6 tolerance example:

FXR705Ø16.350H6LB1G-HP905

Bore diameter d₁ = 16.350 H6

G variant example:

FXR705GØ16.350-5LB1G-HP905

Special tool diameter d₁ = 16.350 -5 μm

Dimensions in mm.

For cutting data recommendations, see end of chapter.

FixReam 700

Expanding design, long, for blind bore
FXR705

Design:

Reamer diameter: 9.900 - 32.200 mm
Lead: LB1G
Cutting material: CP905
Coated cermet

Application:

For surfaces Ra < 2 µm.
The expansion system is therefore only suitable for compensation prior to re-grinding and not for setting or re-adjusting the diameter.

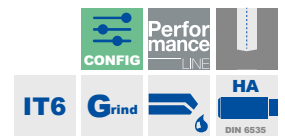
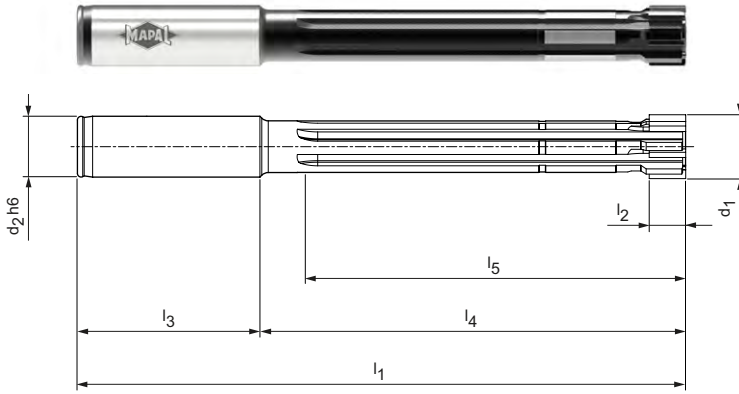

Configurable features



Bore diameter tolerance ≥ IT6:
- Diameter freely selectable in increments of 0.001 mm
- Can be ordered in tolerance ≥ IT6

Specification:
FXR705Ø[Diameter][Tolerance]LB1G-CP905

G variants:
- Diameter freely selectable in increments of 0.001 mm
- Can be ordered from tolerances ≥ 5 µm (G variant, see page 35)

G variant specification:
FXR705GØ[Diameter][Tolerance]LB1G-CP905

Dimensions of configurable series IT6

d ₁	d ₂	l ₁	l ₂	l ₃	l ₄	l ₅	z
9,900 - 15,899	12	160	8	45	115	100	6
15,900 - 18,990	16	180	12	50	130	113	6
18,900 - 25,899	20	200	12	60	140	120	6
25,900 - 32,200	25	210	12	60	150	130	6

IT6 tolerance example:
FXR705Ø16.350H6LB1G-CP905

Bore diameter d₁ = 16.350 H6

G variant example:
FXR705GØ16.350-5LB1G-CP905

Special tool diameter d₁ = 16.350 -5 µm

FixReam 700

Expanding design, long, for blind bore
FXR705

Design:

Reamer diameter: 9.900 - 32.200 mm
Lead: LB1G
Cutting material: HP622
Coated solid carbide

Application:

The expansion system is therefore only suitable for compensation prior to re-grinding and not for setting or re-adjusting the diameter.

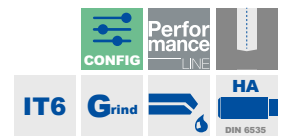
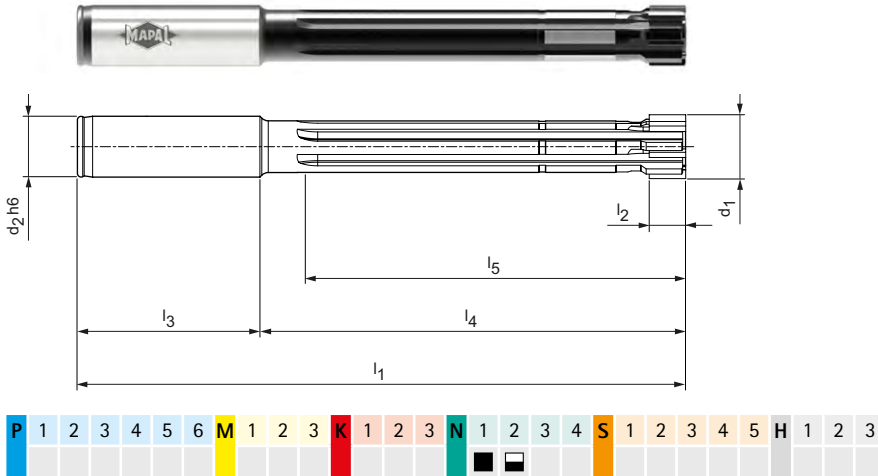

Configurable features



Bore diameter tolerance \geq IT6:

- Diameter freely selectable in increments of 0.001 mm
- Can be ordered in tolerance \geq IT6

Specification:

FXR705Ø[Diameter][Tolerance]LB1G-HP622

G variants:

- Diameter freely selectable in increments of 0.001 mm
- Can be ordered from tolerances $\geq 5 \mu\text{m}$ (G variant, see page 35)

G variant specification:

FXR705GØ[Diameter][Tolerance]LB1G-HP622

Dimensions of configurable series IT6

d_1	d_2	l_1	l_2	l_3	l_4	l_5	z
9,900 - 15,899	12	160	8	45	115	100	6
15,900 - 18,990	16	180	12	50	130	113	6
18,900 - 25,899	20	200	12	60	140	120	6
25,900 - 32,200	25	210	12	60	150	130	6

IT6 tolerance example:

FXR705Ø16.350H6LB1G-HP622

Bore diameter $d_1 = 16.350 \text{ H6}$

G variant example:

FXR705GØ16.350-5LB1G-HP622

Special tool diameter $d_1 = 16.350 -5 \mu\text{m}$

FixReam 700

Expanding design, long, for blind bore
FXR705

Design:

Reamer diameter: 9.900 - 32.200 mm
Lead: LD1G
Cutting material: HP625
Coated solid carbide

Application:

The expansion system is therefore only suitable for compensation prior to re-grinding and not for setting or re-adjusting the diameter.

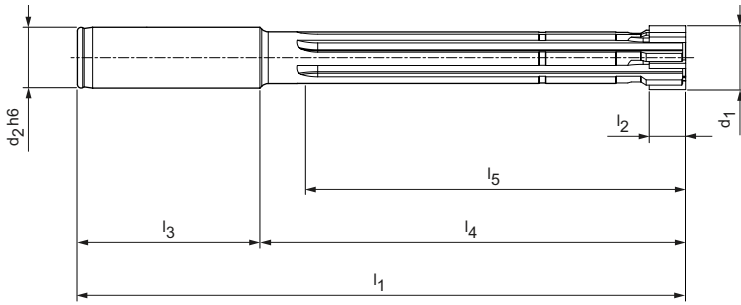

Configurable features



Bore diameter tolerance \geq IT6:
- Diameter freely selectable in increments of 0.001 mm
- Can be ordered in tolerance \geq IT6

Specification:
FXR705Ø[Diameter][Tolerance]LD1G-HP625

G variants:
- Diameter freely selectable in increments of 0.001 mm
- Can be ordered from tolerances \geq 5 μ m (G variant, see page 35)

G variant specification:
FXR705GØ[Diameter][Tolerance]LD1G-HP625

Dimensions of configurable series IT6

d_1	d_2	l_1	l_2	l_3	l_4	l_5	z
9,900 - 15,899	12	160	8	45	115	100	6
15,900 - 18,990	16	180	12	50	130	113	6
18,900 - 25,899	20	200	12	60	140	120	6
25,900 - 32,200	25	210	12	60	150	130	6

IT6 tolerance example:
FXR705Ø16.350H6LD1G-HP625

Bore diameter $d_1 = 16.350$ H6

G variant example:
FXR705GØ16.350-5LD1G-HP625

Special tool diameter $d_1 = 16.350 -5 \mu$ m

FixReam 700

Expanding design, short, for blind bore
FXR703

Design:

Reamer diameter: 9.900 - 32.200 mm
Lead: LB1G
Cutting material: CU111
Uncoated cermet

Application:

The expansion system is therefore only suitable for compensation prior to re-grinding and not for setting or re-adjusting the diameter.

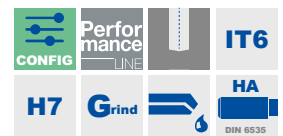
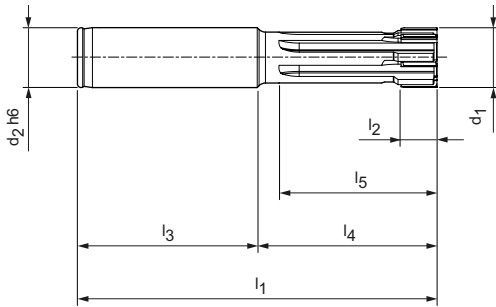

Preferred series in H7

d ₁ H7	Dimensions						z	Specification	Order no.
	d ₂ h6	l ₁	l ₂	l ₃	l ₄	l ₅			
10,000	12	95	8	45	50	38	6	FXR703Ø10.000H7LB1G-CU111	31460983
12,000	12	95	8	45	50	39	6	FXR703Ø12.000H7LB1G-CU111	31460984
14,000	12	95	8	45	50	39	6	FXR703Ø14.000H7LB1G-CU111	31460985
16,000	16	100	12	50	50	38	6	FXR703Ø16.000H7LB1G-CU111	31460986
18,000	16	100	12	50	50	39	6	FXR703Ø18.000H7LB1G-CU111	31460987
20,000	20	120	12	60	60	45	6	FXR703Ø20.000H7LB1G-CU111	31460988
22,000	20	120	12	60	60	45	6	FXR703Ø22.000H7LB1G-CU111	31460989
24,000	20	120	12	60	60	45	6	FXR703Ø24.000H7LB1G-CU111	31460990
25,000	20	120	12	60	60	45	6	FXR703Ø25.000H7LB1G-CU111	31460991
28,000	25	135	12	60	75	60	6	FXR703Ø28.000H7LB1G-CU111	31460992
30,000	25	135	12	60	75	60	6	FXR703Ø30.000H7LB1G-CU111	31460993
32,000	25	135	12	60	75	60	6	FXR703Ø32.000H7LB1G-CU111	31460994

Configurable features



Bore diameter tolerance ≥ IT6:

- Diameter freely selectable in increments of 0.001 mm
- Can be ordered in tolerance ≥ IT6

Specification:

FXR703Ø[**Diameter**][**Tolerance**]LB1G-CU111

G variants:

- Diameter freely selectable in increments of 0.001 mm
- Can be ordered from tolerances ≥ 3 μm (G variant, see page 35)

G variant specification:

FXR703GØ[**Diameter**][**Tolerance**]LB1G-CU111

Dimensions of configurable series IT6

d ₁	d ₂	l ₁	l ₂	l ₃	l ₄	l ₅	z
9,900 - 15,899	12	95	8	45	50	38	6
15,899 - 18,899	16	100	12	50	50	38	6
18,900 - 25,899	20	120	12	60	60	45	6
25,900 - 32,200	25	135	12	60	75	60	6

IT6 tolerance example:

FXR703Ø16.350H6LB1G-CU111

Bore diameter d₁ = 16.350 H6

G variant example:

FXR703GØ16.350-3LB1G-CU111

Special tool diameter d₁ = 16.350 -3 μm

Dimensions in mm.

For cutting data recommendations, see end of chapter.

FixReam 700

Expanding design, short, for blind bore
FXR703

Design:

Reamer diameter: 9.900 - 32.200 mm
Lead: LD1G
Cutting material: HP421
Coated solid carbide

Application:

The expansion system is therefore only suitable for compensation prior to re-grinding and not for setting or re-adjusting the diameter.

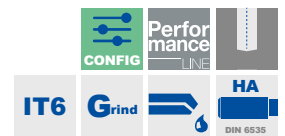
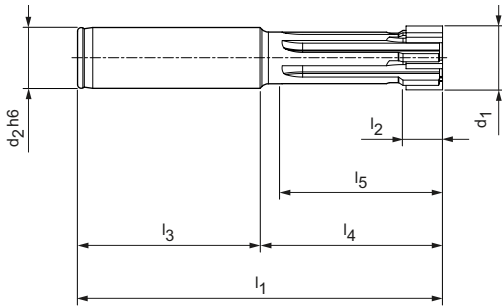

Configurable features



Bore diameter tolerance \geq IT6:
- Diameter freely selectable in increments of 0.001 mm
- Can be ordered in tolerance \geq IT6

Specification:
FXR703Ø[Diameter][Tolerance]LD1G-HP421

G variants:
- Diameter freely selectable in increments of 0.001 mm
- Can be ordered from tolerances \geq 5 μ m (G variant, see page 35)

G variant specification:
FXR703GØ[Diameter][Tolerance]LD1G-HP421

Dimensions of configurable series IT6

d_1	d_2	l_1	l_2	l_3	l_4	l_5	z
9,900 - 15,899	12	95	8	45	50	45	6
15,900 - 18,990	16	100	12	50	50	45	6
18,900 - 25,899	20	120	12	60	60	55	6
25,900 - 32,200	25	135	12	60	75	70	6

IT6 tolerance example:
FXR703Ø16.350H6LD1G-HP421

Bore diameter $d_1 = 16.350$ H6

G variant example:
FXR703GØ16.350-5LD1G-HP421

Special tool diameter $d_1 = 16.350 -5 \mu$ m

FixReam 700

Expanding design, short, for blind bore
FXR703

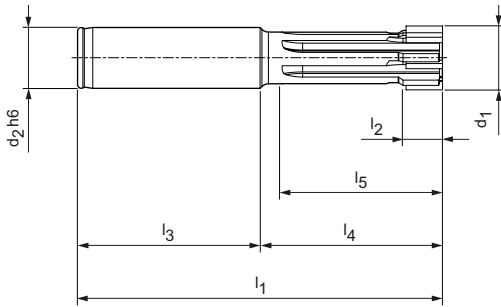

Design:

Reamer diameter: 9.900 - 32.200 mm
Lead: LB1G
Cutting material: HP905
Coated solid carbide

Application:

The expansion system is therefore only suitable for compensation prior to re-grinding and not for setting or re-adjusting the diameter.

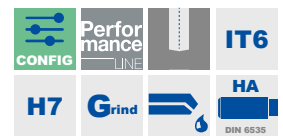

Preferred series in H7

d ₁ H7	Dimensions						z	Specification	Order no.
	d ₂ h6	l ₁	l ₂	l ₃	l ₄	l ₅			
10,000	12	95	8	45	50	38	6	FXR703Ø10.000H7LB1G-HP905	31553819
12,000	12	95	8	45	50	39	6	FXR703Ø12.000H7LB1G-HP905	31553820
14,000	12	95	8	45	50	39	6	FXR703Ø14.000H7LB1G-HP905	31553821
16,000	16	100	12	50	50	38	6	FXR703Ø16.000H7LB1G-HP905	31553822
18,000	16	100	12	50	50	39	6	FXR703Ø18.000H7LB1G-HP905	31553823
20,000	20	120	12	60	60	45	6	FXR703Ø20.000H7LB1G-HP905	31553824
22,000	20	120	12	60	60	45	6	FXR703Ø22.000H7LB1G-HP905	31553825
24,000	20	120	12	60	60	45	6	FXR703Ø24.000H7LB1G-HP905	31553826
25,000	20	120	12	60	60	45	6	FXR703Ø25.000H7LB1G-HP905	31553827
28,000	25	135	12	60	75	60	6	FXR703Ø28.000H7LB1G-HP905	31553828
30,000	25	135	12	60	75	60	6	FXR703Ø30.000H7LB1G-HP905	31553829
32,000	25	135	12	60	75	60	6	FXR703Ø32.000H7LB1G-HP905	31553830

Configurable features



Bore diameter tolerance ≥ IT6:

- Diameter freely selectable in increments of 0.001 mm
- Can be ordered in tolerance ≥ IT6

Specification:

FXR703Ø[Diameter][Tolerance]LB1G-HP905

G variants:

- Diameter freely selectable in increments of 0.001 mm
- Can be ordered from tolerances ≥ 5 μm (G variant, see page 35)

G variant specification:

FXR703GØ[Diameter][Tolerance]LB1G-HP905

Dimensions of configurable series IT6

d ₁	d ₂	l ₁	l ₂	l ₃	l ₄	l ₅	z
9,900 - 15,899	12	95	8	45	50	45	6
15,900 - 18,899	16	100	12	50	50	45	6
18,900 - 25,899	20	120	12	60	60	55	6
25,900 - 32,200	25	135	12	60	75	70	6

IT6 tolerance example:

FXR703Ø16.350H6LB1G-HP905

Bore diameter d₁ = 16.350 H6

G variant example:

FXR703GØ16.350-5LB1G-HP905

Special tool diameter d₁ = 16.350 -5 μm

Dimensions in mm.

For cutting data recommendations, see end of chapter.

FixReam 700

Expanding design, short, for blind bore
FXR703

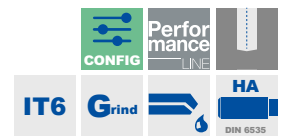
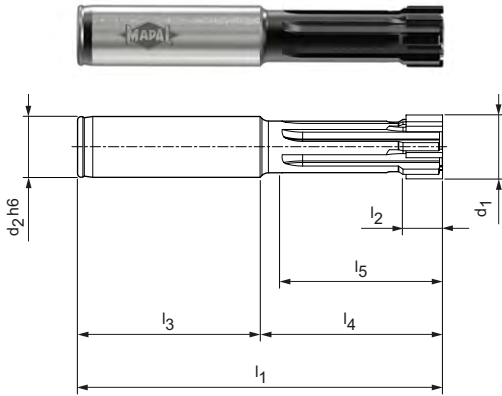

Design:
Reamer diameter: 9.900 - 32.200 mm
Lead: LB1G
Cutting material: CP905
Coated cermet

Application:
For surfaces Ra < 2 µm.
The expansion system is therefore only suitable for compensation prior to re-grinding and not for setting or re-adjusting the diameter.

Configurable features



Bore diameter tolerance ≥ IT6:
- Diameter freely selectable in increments of 0.001 mm
- Can be ordered in tolerance ≥ IT6

Specification:
FXR703Ø[Diameter][Tolerance]LB1G-CP905

G variants:
- Diameter freely selectable in increments of 0.001 mm
- Can be ordered from tolerances ≥ 5 µm (G variant, see page 35)

G variant specification:
FXR703GØ[Diameter][Tolerance]LB1G-CP905

Dimensions of configurable series IT6

d ₁	d ₂	l ₁	l ₂	l ₃	l ₄	l ₅	z
9,900 - 15,899	12	95	8	45	50	45	6
15,900 - 18,990	16	100	12	50	50	45	6
18,900 - 25,899	20	120	12	60	60	55	6
25,900 - 32,200	25	135	12	60	75	70	6

IT6 tolerance example:
FXR703Ø16.350H6LB1G-CP905

Bore diameter d₁ = 16.350 H6

G variant example:
FXR703GØ16.350-5LB1G-CP905

Special tool diameter d₁ = 16.350 -5 µm

FixReam 700

Expanding design, short, for blind bore
FXR703

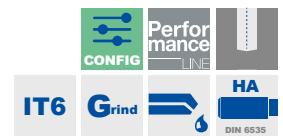
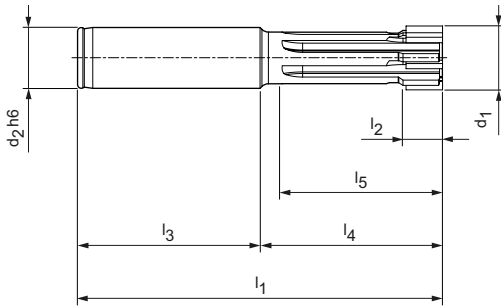

Design:
Reamer diameter: 9.900 - 32.200 mm
Lead: LB1G
Cutting material: HP622
Coated solid carbide

Application:
The expansion system is therefore only suitable for compensation prior to re-grinding and not for setting or re-adjusting the diameter.

Configurable features



Bore diameter tolerance \geq IT6:

- Diameter freely selectable in increments of 0.001 mm
- Can be ordered in tolerance \geq IT6

Specification:

FXR703Ø[Diameter][Tolerance]LB1G-HP622

G variants:

- Diameter freely selectable in increments of 0.001 mm
- Can be ordered from tolerances $\geq 5 \mu\text{m}$ (G variant, see page 35)

G variant specification:

FXR703GØ[Diameter][Tolerance]LB1G-HP622

Dimensions of configurable series IT6

d_1	d_2	l_1	l_2	l_3	l_4	l_5	z
9,900 - 15,899	12	95	8	45	50	45	6
15,900 - 18,990	16	100	12	50	50	45	6
18,900 - 25,899	20	120	12	60	60	55	6
25,900 - 32,200	25	135	12	60	75	70	6

IT6 tolerance example:

FXR703Ø16.350H6LB1G-HP622

Bore diameter $d_1 = 16.350 \text{ H6}$

G variant example:

FXR703GØ16.350-5LB1G-HP622

Special tool diameter $d_1 = 16.350 -5 \mu\text{m}$

FixReam 700

Expanding design, short, for blind bore
FXR703

Design:

Reamer diameter: 9.900 - 32.200 mm
Lead: LD1G
Cutting material: HP625
Coated solid carbide

Application:

The expansion system is therefore only suitable for compensation prior to re-grinding and not for setting or re-adjusting the diameter.

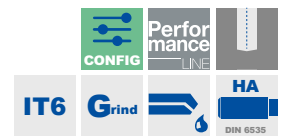
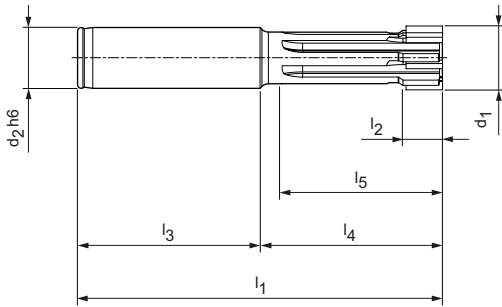

Configurable features



Bore diameter tolerance \geq IT6:
- Diameter freely selectable in increments of 0.001 mm
- Can be ordered in tolerance \geq IT6

Specification:
FXR703Ø[Diameter][Tolerance]LD1G-HP625

G variants:
- Diameter freely selectable in increments of 0.001 mm
- Can be ordered from tolerances \geq 5 μ m (G variant, see page 35)

G variant specification:
FXR703GØ[Diameter][Tolerance]LD1G-HP625

Dimensions of configurable series IT6

d_1	d_2	l_1	l_2	l_3	l_4	l_5	z
9,900 - 15,899	12	95	8	45	50	45	6
15,900 - 18,990	16	100	12	50	50	45	6
18,900 - 25,899	20	120	12	60	60	55	6
25,900 - 32,200	25	135	12	60	75	70	6

IT6 tolerance example:
FXR703Ø16.350H6LD1G-HP625

Bore diameter $d_1 = 16.350$ H6

G variant example:
FXR703GØ16.350-5LD1G-HP625

Special tool diameter $d_1 = 16.350 -5 \mu$ m

Cutting data recommendation for FixReam 700

Feed and cutting speed

FXR700 | FXR705

Cutting material: CU111 | Lead: LA1G | LB1G

MMG*		Workpiece material	Strength/ Hardness [N/mm ²] [HRC]	Cutting speed v_c [m/min]		Feed f_z		Stock removal a_p [mm] for tool diameter	
				z 6					
				Internal cooling		9.900 - 32.200	9.900 - 15.899	15.900 - 32.200	
P	P1	P1.1	Structural, free-cutting, case hardened and heat-treated steels, non-alloy	< 700	120	0.15	0.10	0.15	
		P1.2	Structural, free-cutting, case hardened and heat-treated steels, non-alloy	< 1,200	120	0.15	0.10	0.15	
	P2	P2.1	Nitrided, case hardened and heat-treated steels, alloy	< 900	120	0.15	0.10	0.15	
		P2.2	Nitrided, case hardened and heat-treated steels, alloy	< 1,400	100	0.10	0.10	0.15	
	P3	P3.1	Tool, bearing, spring and high-speed steels**	< 800	100	0.15	0.10	0.15	
		P3.2	Tool, bearing, spring and high-speed steels**	< 1,000	100	0.15	0.10	0.15	
		P3.3	Tool, bearing, spring and high-speed steels**	< 1,500	80	0.10	0.10	0.15	
K	K1	K1.1	Cast iron with lamellar graphite (grey cast iron), GJL	< 300	120	0.20	0.10	0.15	
	K2	K2.1	Cast iron with spheroidal graphite, GJS	< 500	120	0.20	0.10	0.15	

FXR702 | FXR703

Cutting material: CU111 | Lead: LA1G | LB1G

MMG*		Workpiece material	Strength/ Hardness [N/mm ²] [HRC]	Cutting speed v_c [m/min]		Feed f_z		Stock removal a_p [mm] for tool diameter	
				z 6					
				Internal cooling		9.900 - 32.200	9.900 - 15.899	15.900 - 32.200	
P	P1	P1.1	Structural, free-cutting, case hardened and heat-treated steels, non-alloy	< 700	150	0.15	0.10	0.15	
		P1.2	Structural, free-cutting, case hardened and heat-treated steels, non-alloy	< 1,200	150	0.15	0.10	0.15	
	P2	P2.1	Nitrided, case hardened and heat-treated steels, alloy	< 900	150	0.15	0.10	0.15	
		P2.2	Nitrided, case hardened and heat-treated steels, alloy	< 1,400	130	0.10	0.10	0.15	
	P3	P3.1	Tool, bearing, spring and high-speed steels**	< 800	130	0.15	0.10	0.15	
		P3.2	Tool, bearing, spring and high-speed steels**	< 1,000	130	0.15	0.10	0.15	
		P3.3	Tool, bearing, spring and high-speed steels**	< 1,500	120	0.10	0.10	0.15	
K	K1	K1.1	Cast iron with lamellar graphite (grey cast iron), GJL	< 300	150	0.20	0.10	0.15	
	K2	K2.1	Cast iron with spheroidal graphite, GJS	< 500	150	0.20	0.10	0.15	

* MAPAL Machining Groups

** If the alloy parts Cr, Mo, Ni, V, W in total > 8%, then select the next highest MAPAL machining group.

The specified cutting data are guide values.

The optimum data for the respective machining task should be determined during the test or machining.

Cutting data recommendation for FixReam 700

Feed and cutting speed

FXR700 / FXR705

Cutting material: HP905 | Lead: LA1G | LB1G

MMG*		Workpiece material	Strength/ Hardness [N/mm ²] [HRC]	Cutting speed v_c [m/min]		Feed f_z		Stock removal a_p [mm] for tool diameter	
				Internal cooling	z 6	9.900 - 32.200	9.900 - 15.899	15.900 - 32.200	
P	P1	P1.1	Structural, free-cutting, case hardened and heat-treated steels, non-alloy	< 700	120	0.15	0.10	0.15	
		P1.2	Structural, free-cutting, case hardened and heat-treated steels, non-alloy	< 1,200	120	0.15	0.10	0.15	
	P2	P2.1	Nitrided, case hardened and heat-treated steels, alloy	< 900	110	0.15	0.10	0.15	
		P2.2	Nitrided, case hardened and heat-treated steels, alloy	< 1,400	110	0.10	0.10	0.15	
	P3	P3.1	Tool, bearing, spring and high-speed steels**	< 800	100	0.15	0.10	0.15	
		P3.2	Tool, bearing, spring and high-speed steels**	< 1,000	100	0.15	0.10	0.15	
		P3.3	Tool, bearing, spring and high-speed steels**	< 1,500	80	0.10	0.10	0.15	
	P4	P4.1	Stainless steels, ferritic and martensitic		40	0.08	0.10	0.10	
	P5	P5.1	Cast steel		110	0.15	0.10	0.15	
	K	K1	K1.1	Cast iron with lamellar graphite (grey cast iron), GJL	< 300	120	0.20	0.10	0.15
K2.1			Cast iron with spheroidal graphite, GJS	< 500	120	0.20	0.10	0.15	
K2		K2.2	Cast iron with spheroidal graphite, GJS	≤ 800	90	0.20	0.10	0.15	
		K2.3	Cast iron with spheroidal graphite, GJS	> 800	90	0.15	0.10	0.15	
K3		K3.1	Cast iron with spheroidal graphite, GJV; malleable cast iron, GJM	< 500	90	0.15	0.10	0.15	
		K3.2	Cast iron with spheroidal graphite, GJV; malleable cast iron, GJM	> 500	90	0.15	0.10	0.15	
N	N3	N3.1	Graphite > 8 μm		80	0.08	0.10	0.15	
		N3.2	Graphite < 8 μm		80	0.08	0.10	0.15	

FXR702 | FXR703

Cutting material: HP905 | Lead: LA1G | LB1G

MMG*		Workpiece material	Strength/ Hardness [N/mm ²] [HRC]	Cutting speed v_c [m/min]		Feed f_z		Stock removal a_p [mm] for tool diameter	
				Internal cooling	z 6	9.900 - 32.200	9.900 - 15.899	15.900 - 32.200	
P	P1	P1.1	Structural, free-cutting, case hardened and heat-treated steels, non-alloy	< 700	140	0.15	0.10	0.15	
		P1.2	Structural, free-cutting, case hardened and heat-treated steels, non-alloy	< 1,200	140	0.15	0.10	0.15	
	P2	P2.1	Nitrided, case hardened and heat-treated steels, alloy	< 900	130	0.15	0.10	0.15	
		P2.2	Nitrided, case hardened and heat-treated steels, alloy	< 1,400	130	0.10	0.10	0.15	
	P3	P3.1	Tool, bearing, spring and high-speed steels**	< 800	120	0.15	0.10	0.15	
		P3.2	Tool, bearing, spring and high-speed steels**	< 1,000	120	0.15	0.10	0.15	
		P3.3	Tool, bearing, spring and high-speed steels**	< 1,500	100	0.10	0.10	0.15	
	P4	P4.1	Stainless steels, ferritic and martensitic		40	0.08	0.10	0.10	
	P5	P5.1	Cast steel		130	0.15	0.10	0.15	
	K	K1	K1.1	Cast iron with lamellar graphite (grey cast iron), GJL	< 300	140	0.20	0.10	0.15
K2.1			Cast iron with spheroidal graphite, GJS	< 500	140	0.20	0.10	0.15	
K2		K2.2	Cast iron with spheroidal graphite, GJS	≤ 800	110	0.20	0.10	0.15	
		K2.3	Cast iron with spheroidal graphite, GJS	> 800	110	0.15	0.10	0.15	
K3		K3.1	Cast iron with spheroidal graphite, GJV; malleable cast iron, GJM	< 500	110	0.15	0.10	0.15	
		K3.2	Cast iron with spheroidal graphite, GJV; malleable cast iron, GJM	> 500	110	0.15	0.10	0.15	
N	N3	N3.1	Graphite > 8 μm		80	0.08	0.10	0.15	
		N3.2	Graphite < 8 μm		80	0.08	0.10	0.15	

* MAPAL Machining Groups

** If the alloy parts Cr, Mo, Ni, V, W in total > 8%, then select the next highest MAPAL machining group.

The specified cutting data are guide values.

The optimum data for the respective machining task should be determined during the test or machining.

Cutting data recommendation for FixReam 700

Feed and cutting speed

FXR700 | FXR705

Cutting material: CP905 | Lead: LA1G | LB1G

MMG*		Workpiece material	Strength/ Hardness [N/mm ²] [HRC]	Cutting speed v_c [m/min]		Feed f_z		Stock removal a_p [mm] for tool diameter	
				z 6					
				Internal cooling		9.900 - 32.200	9.900 - 15.899	15.900 - 32.200	
K	K1	K1.1	Cast iron with lamellar graphite (grey cast iron), GJL	< 300	120	0.20	0.10	0.15	
	K2	K2.1	Cast iron with spheroidal graphite, GJS	< 500	120	0.20	0.10	0.15	
		K2.2	Cast iron with spheroidal graphite, GJS	≤ 800	100	0.20	0.10	0.15	

FXR702 | FXR703

Cutting material: CP905 | Lead: LA1G | LB1G

MMG*		Workpiece material	Strength/ Hardness [N/mm ²] [HRC]	Cutting speed v_c [m/min]		Feed f_z		Stock removal a_p [mm] for tool diameter	
				z 6					
				Internal cooling		9.900 - 32.200	9.900 - 15.899	15.900 - 32.200	
K	K1	K1.1	Cast iron with lamellar graphite (grey cast iron), GJL	< 300	140	0.20	0.10	0.15	
	K2	K2.1	Cast iron with spheroidal graphite, GJS	< 500	140	0.20	0.10	0.15	
		K2.2	Cast iron with spheroidal graphite, GJS	≤ 800	120	0.20	0.10	0.15	

FXR700 | FXR702 | FXR703 | FXR705

Cutting material: HP421 | Lead: LC1G | LD1G

MMG*		Workpiece material	Strength/ Hardness [N/mm ²] [HRC]	Cutting speed v_c [m/min]		Feed f_z		Stock removal a_p [mm] for tool diameter	
				z 6					
				Internal cooling		9.900 - 32.200	9.900 - 15.899	15.900 - 32.200	
P	P4	P4.1	Stainless steels, ferritic and martensitic		40	0.08	0.10		
	P6	P6.1	Stainless cast steel, ferritic and martensitic		40	0.08	0.10		
M	M1	M1.1	Stainless steels, austenitic	< 700	40	0.08	0.10		
		M1.2	Stainless steels, ferritic/austenitic (duplex)	< 1,000	20	0.08	0.10		
	M2	M2.1	Stainless/heat-resistant cast steel, austenitic	< 700	40	0.08	0.10		
	M3	M3.1	Stainless cast steel, ferritic/austenitic (duplex)	< 1,000	20	0.08	0.10		

* MAPAL Machining Groups

The specified cutting data are guide values.

The optimum data for the respective machining task should be determined during the test or machining.

Cutting data recommendation for FixReam 700

Feed and cutting speed

FXR700 | FXR702 | FXR703 | FXR705

Cutting material: HP625 | Lead: LC1G | LD1G

MMG*		Workpiece material	Strength/ Hardness [N/mm ²] [HRC]	Cutting speed v _c [m/min]		Feed f _z		Stock removal a _p [mm] for tool diameter	
				z 6		z 6			
				Internal cooling		9.900 - 32.200		9.900 - 15.899	
S	S1	S1.1	Titanium, titanium alloys	< 400	20	0.08		0.10	
	S2	S2.1	Titanium, titanium alloys	< 1,200	20	0.08		0.10	
		S2.2	Titanium, titanium alloys	> 1,200	20	0.08		0.10	
		S3.1	Nickel, non-alloy and alloy	< 900	20	0.08		0.10	
	S3	S3.2	Nickel, non-alloy and alloy	> 900	20	0.08		0.10	
		S4	S4.1	High-temperature super alloy Ni, Co and Fe-based		20	0.08		0.10
	S5	S5.1	Tungsten and molybdenum alloys		20	0.08		0.10	

FXR700 | FXR705

Cutting material: HP622 | Lead: LA1G | LB1G

MMG*		Workpiece material	Strength/ Hardness [N/mm ²] [HRC]	Cutting speed v _c [m/min]		Feed f _z		Stock removal a _p [mm] for tool diameter		
				z 6		z 6				
				Internal cooling		9.900 - 32.200		9.900 - 15.899		15.900 - 32.200
N	N1	N1.1	Aluminium, unalloyed and alloyed < 3 % Si		150	0.20		0.10	0.15	
		N1.2	Aluminium, alloyed ≤ 7 % Si		150	0.20		0.10	0.15	
		N1.3	Aluminium, alloyed > 7-12 % Si		150	0.20		0.10	0.15	
	N2	N2.1	Copper, non-alloy and low-alloy	< 300	100	0.20		0.10	0.15	
		N2.2	Copper, alloy	> 300	100	0.20		0.10	0.15	
		N2.3	N2.3	Brass, bronze, gunmetal	< 1,200	100	0.10		0.10	0.15

FXR702 | FXR703

Cutting material: HP622 | Lead: LA1G | LB1G

MMG*		Workpiece material	Strength/ Hardness [N/mm ²] [HRC]	Cutting speed v _c [m/min]		Feed f _z		Stock removal a _p [mm] for tool diameter		
				z 6		z 6				
				Internal cooling		9.900 - 32.200		9.900 - 15.899		15.900 - 32.200
N	N1	N1.1	Aluminium, unalloyed and alloyed < 3 % Si		200	0.20		0.10	0.15	
		N1.2	Aluminium, alloyed ≤ 7 % Si		200	0.20		0.10	0.15	
		N1.3	Aluminium, alloyed > 7-12 % Si		150	0.20		0.10	0.15	
	N2	N2.1	Copper, non-alloy and low-alloy	< 300	150	0.20		0.10	0.15	
		N2.2	Copper, alloy	> 300	150	0.20		0.10	0.15	
		N2.3	N2.3	Brass, bronze, gunmetal	< 1,200	100	0.10		0.10	0.15

* MAPAL Machining Groups

The specified cutting data are guide values.

The optimum data for the respective machining task should be determined during the test or machining.

G variant

Tolerances, lead geometry, chip shape and rake angle

Tolerances for the G variant/fixed variant FXRXX

Cutting material	Diameter range
	Ø 9.900 - 32.200 mm
Uncoated	
CU111	-0.003
Coated	
HP421	-0.005
HP625	-0.005
HP622	-0.005
HP905	-0.005
CP905	-0.005

Lead geometry and rake angles

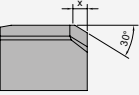
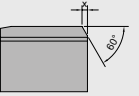
Geometry	Lead geometry			
	Name	Ø area	Lead length x	Geometry
	LA / LC**	9.900 - 11.700 mm	0.80 mm	30°
		11.701 - 32.200 mm	1.00 mm	
	LB / LD**	9.900 - 32.000 mm	0.25 mm	60°

** VA geometry

G variant

The G variant indicates the tool diameter of the reamer with our manufacturing tolerances. The manufacturing tolerances depend on the cutting material (see permissible smallest tolerances for the G variant).

Chip shape / rake angle

Rake angle	
Name	Angle
1G	6°



Discover tool and service solutions now that give you a lead:

BORE MACHINING

REAMING | FINE BORING

DRILLING FROM SOLID | BORING | COUNTERSINKING

MILLING

CLAMPING

TURNING

ACTUATING

SETTING | MEASURING | DISPENSING

SERVICES

FOLLOW US

