

K

GEARBOX

Various face and corner milling operations

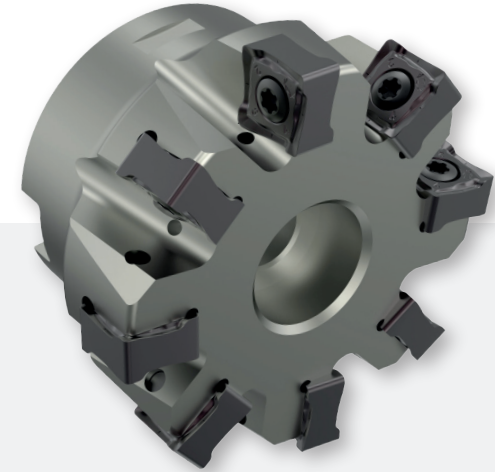
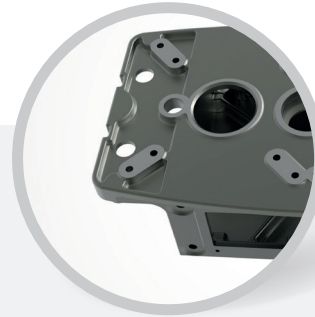

	■	■
Material	EN-GJL-250 (GG25)	
Tool	Corner Mill	Corner Mill NeoMill®-8-Corner
Insert	WSP	SNMU120512R-M05-HP975
Tool-Ø [mm]	63	
Tooth t	7	8
Cutting edges per insert	4	8
Coolant	dry	
v_c [m/min]	336	238
f_z [mm]	0,19	0,27
v_f [mm/min]	2.295	2.600
a_p [mm]	3	
a_e [mm]	10 – 25	
Number of cuts	7	6

Machined parts

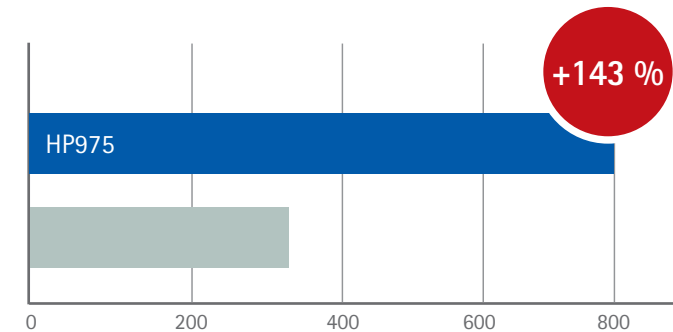

- Cycle time reduction of 13 %
- Tool life increased by 143 %
- CPP reduced by 65 %